

ADAPT Parasol EXb

Installation – Commissioning – Maintenance

20160503

Installation

(A)

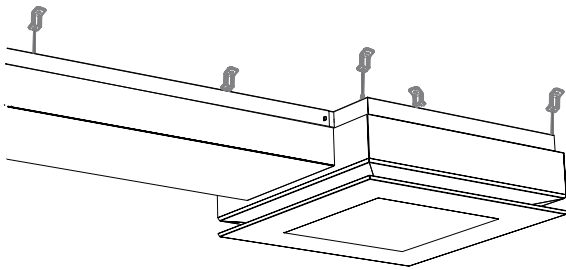

(B)

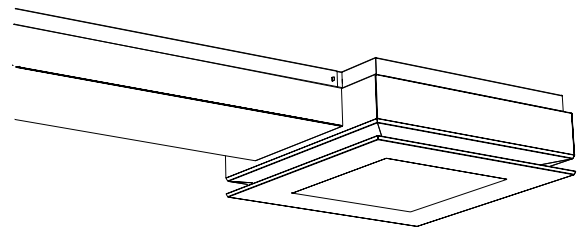

A1, B1

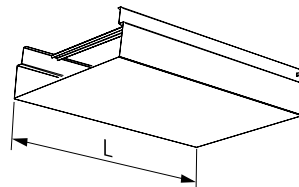
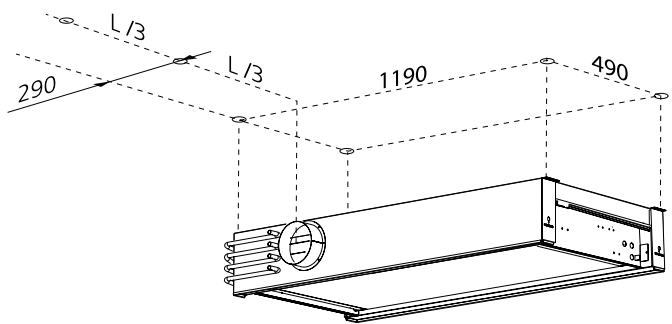
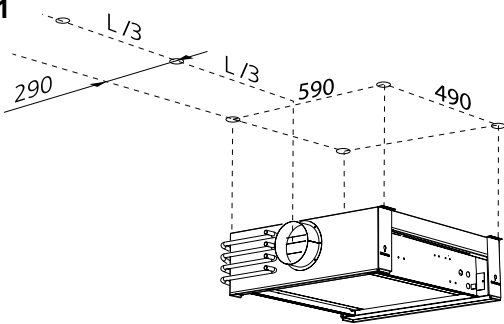

A2

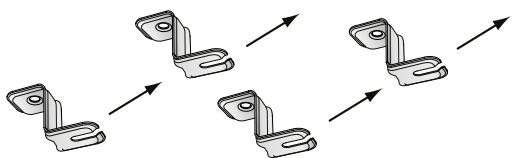
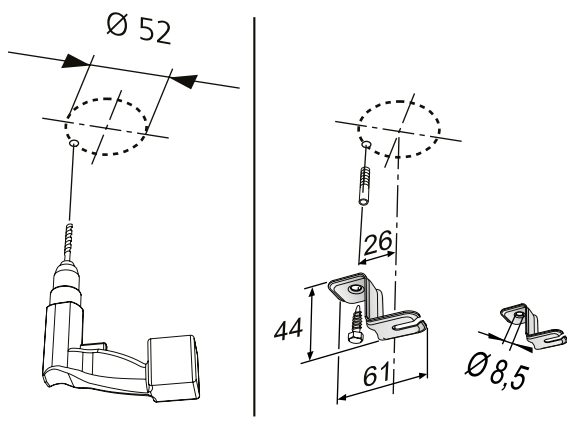

B2

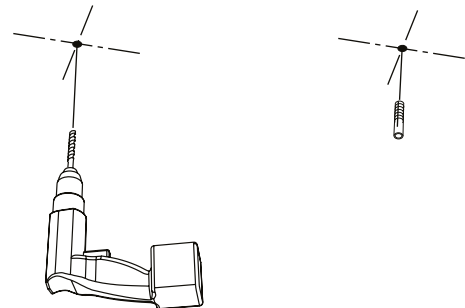

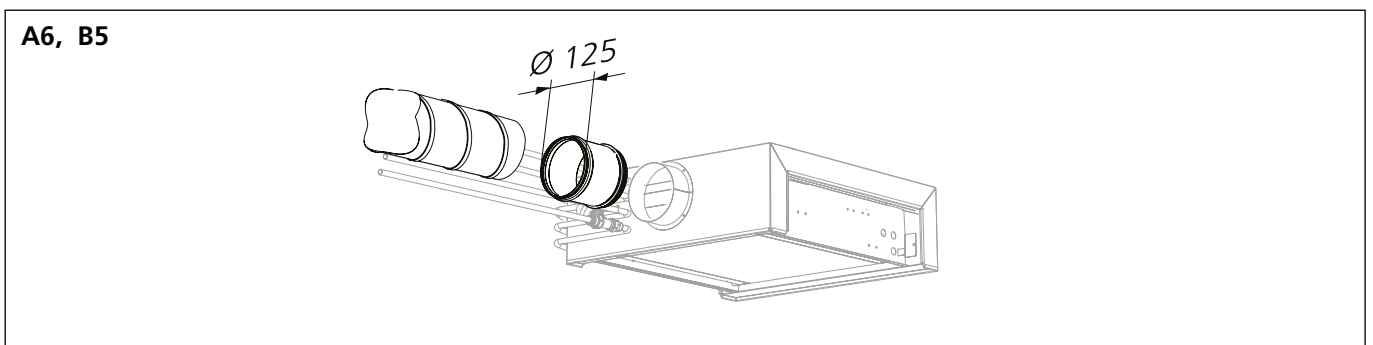
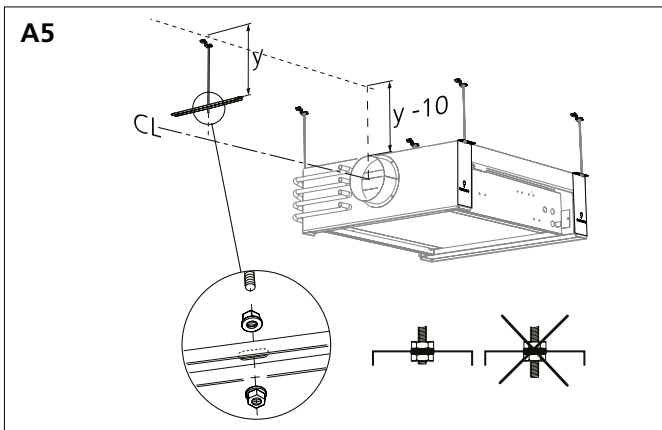
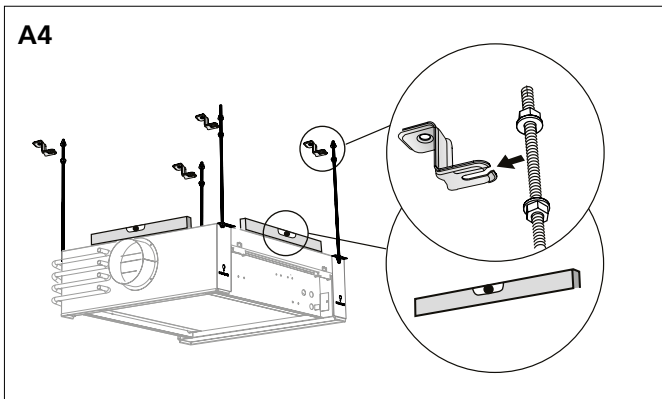
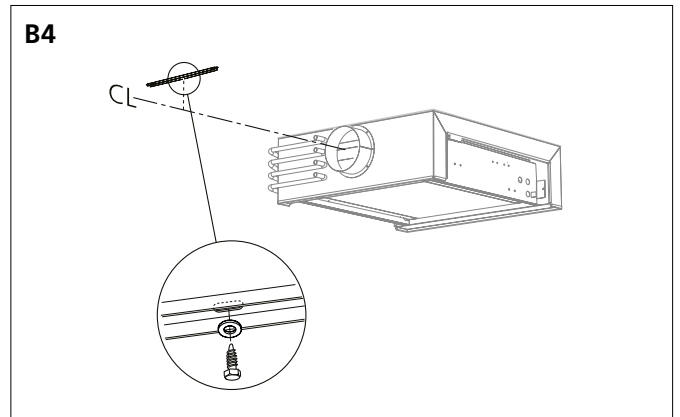
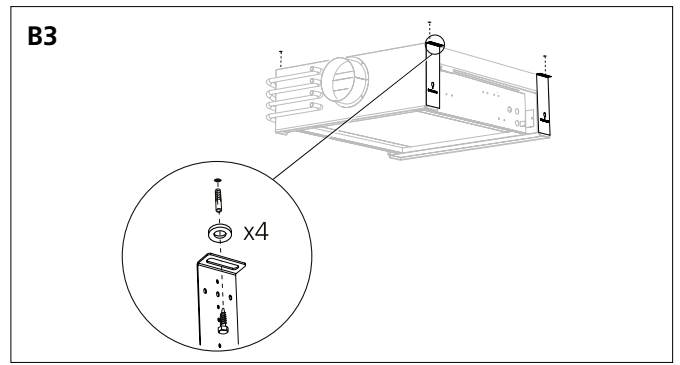
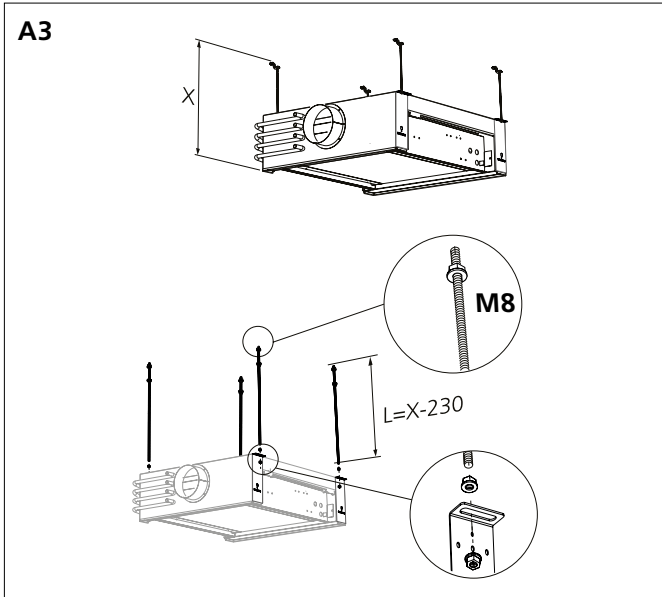

Water

A7, B6

Cu Ø12 x 1,0mm

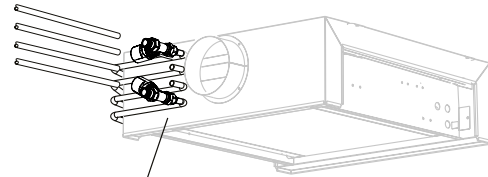
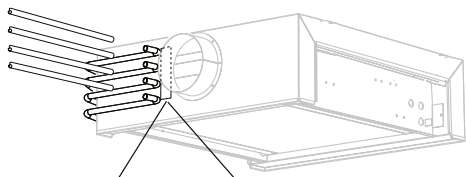

| EX 690 | | EX 1290 | |
|----------------------------------|--|----------------------------------|--|
| Värme retur/ Heating return | | Värme retur/ Heating return | |
| Värme tillopp/ Heating supply | | Kyla tillopp/ Cooling supply | |
| Kyla tillopp/ Cooling supply | | Värme tillopp/ Heating supply | |
| Kyla retur/ Cooling return | | Kyla retur/ Cooling return | |

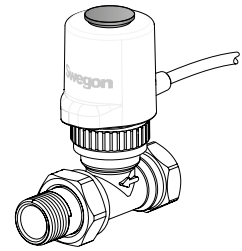
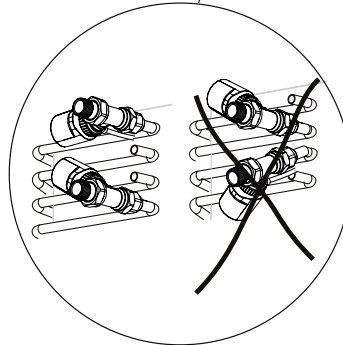

DN15 (1/2") male threads

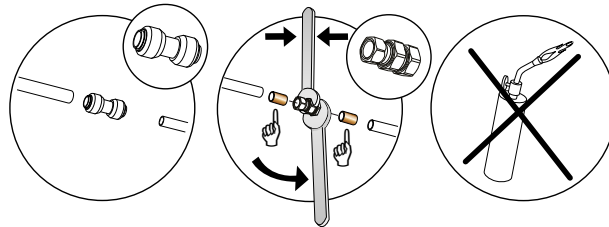

Note that clamp ring couplings require support sleeves inside the pipes.

Control equipment

A8, B7

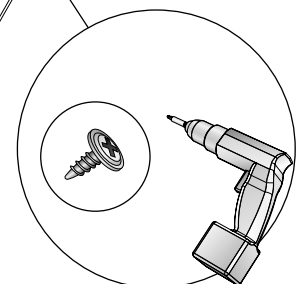
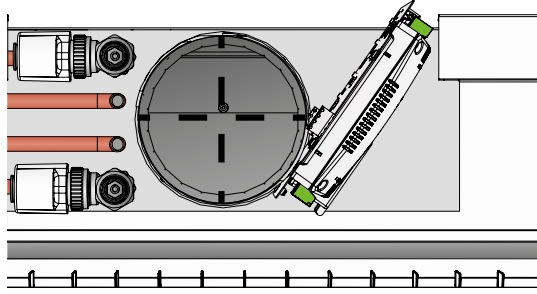
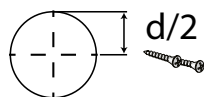
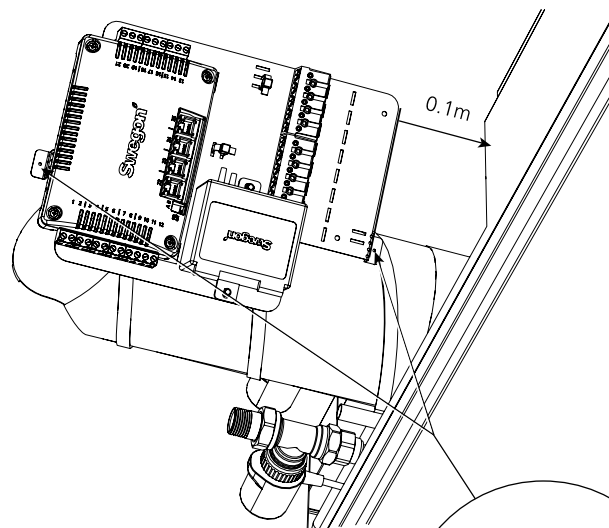
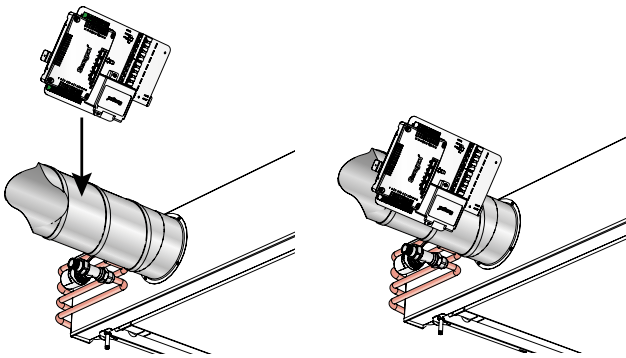

Wiring

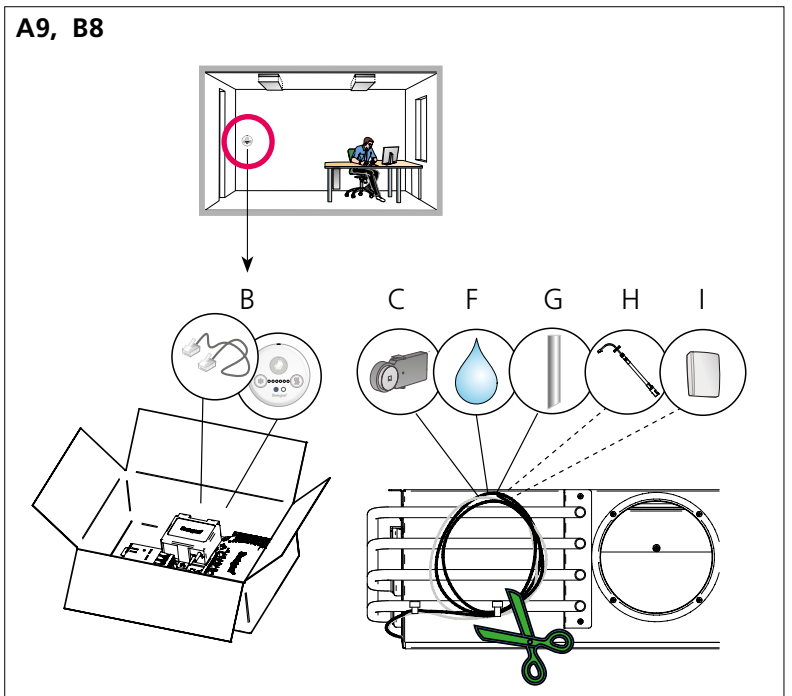
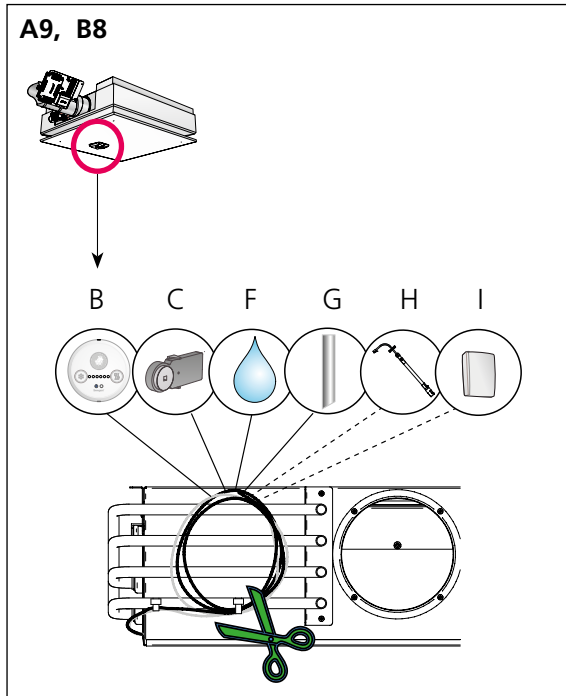

A10, B9

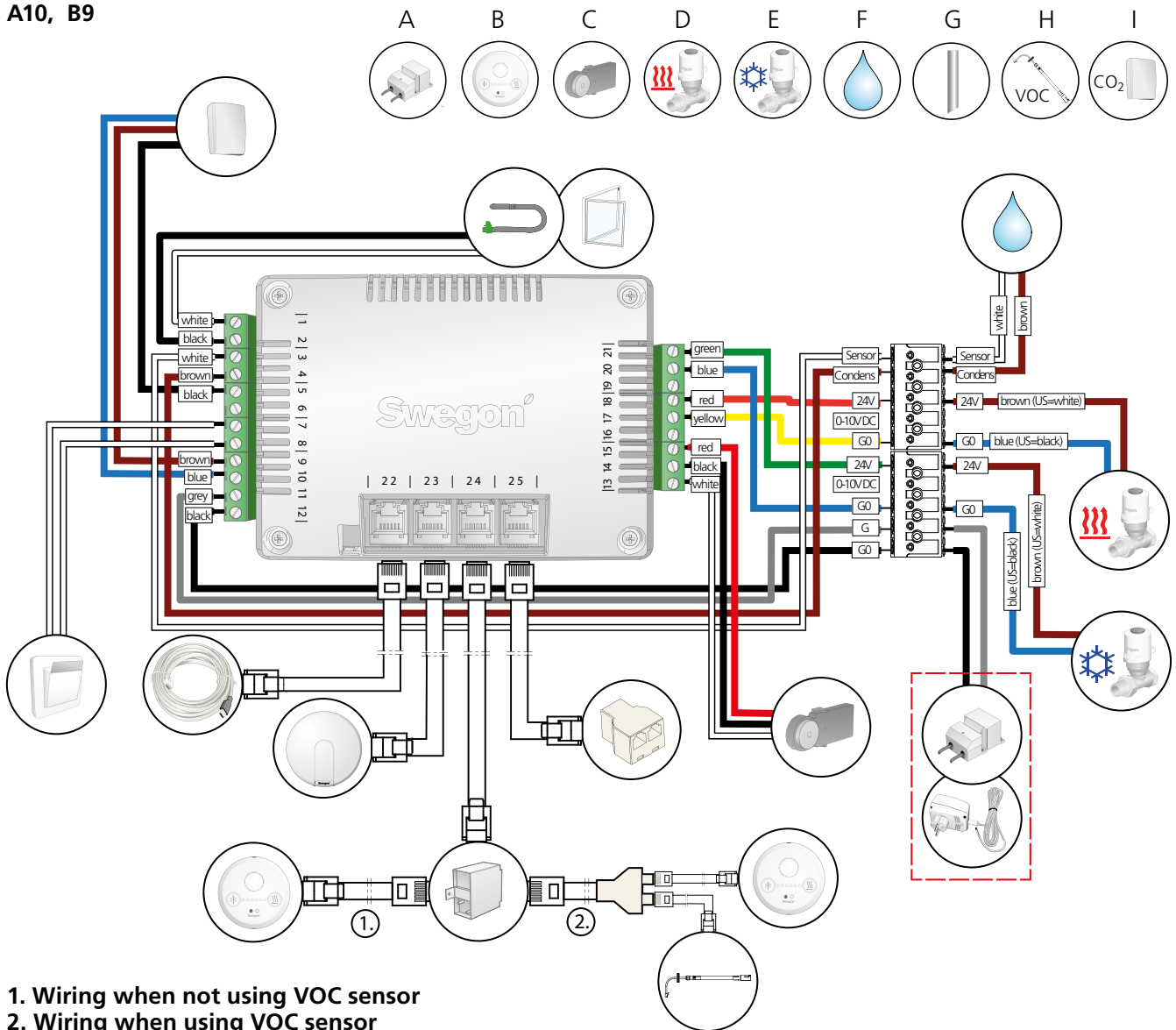

1. Wiring when not using VOC sensor
2. Wiring when using VOC sensor

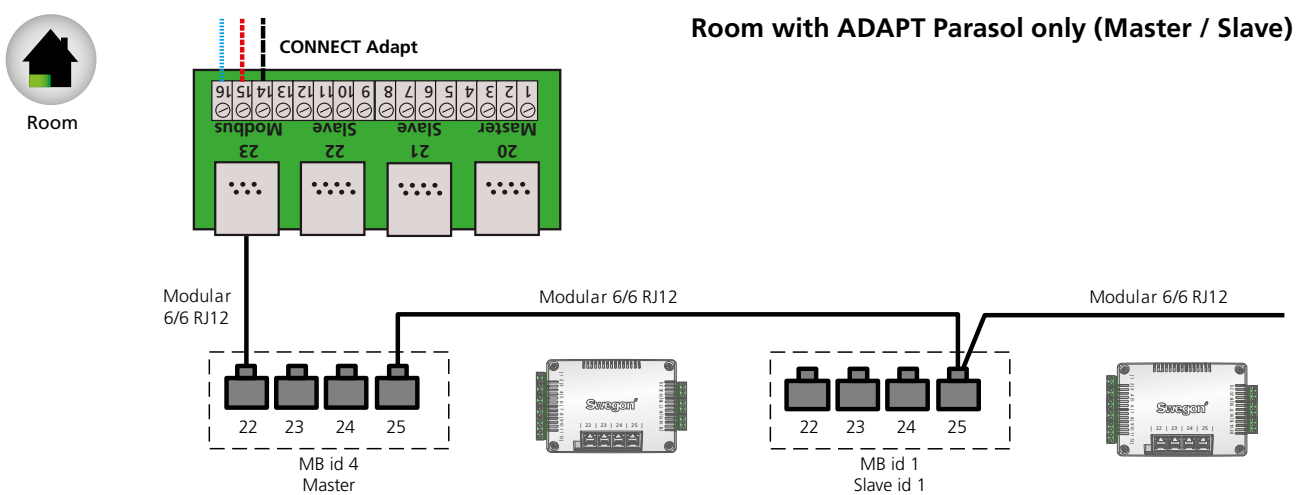
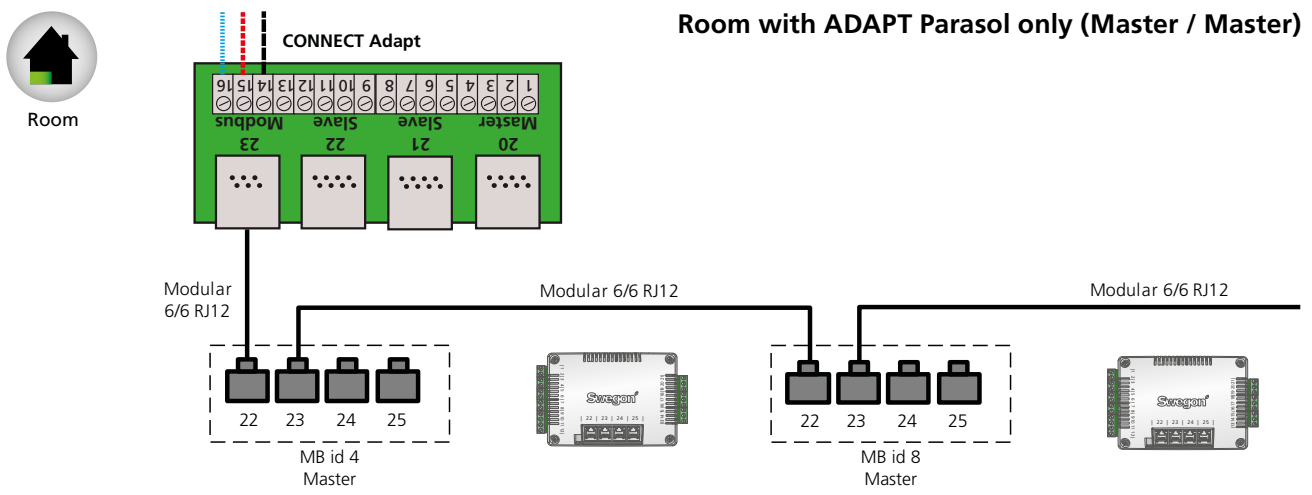
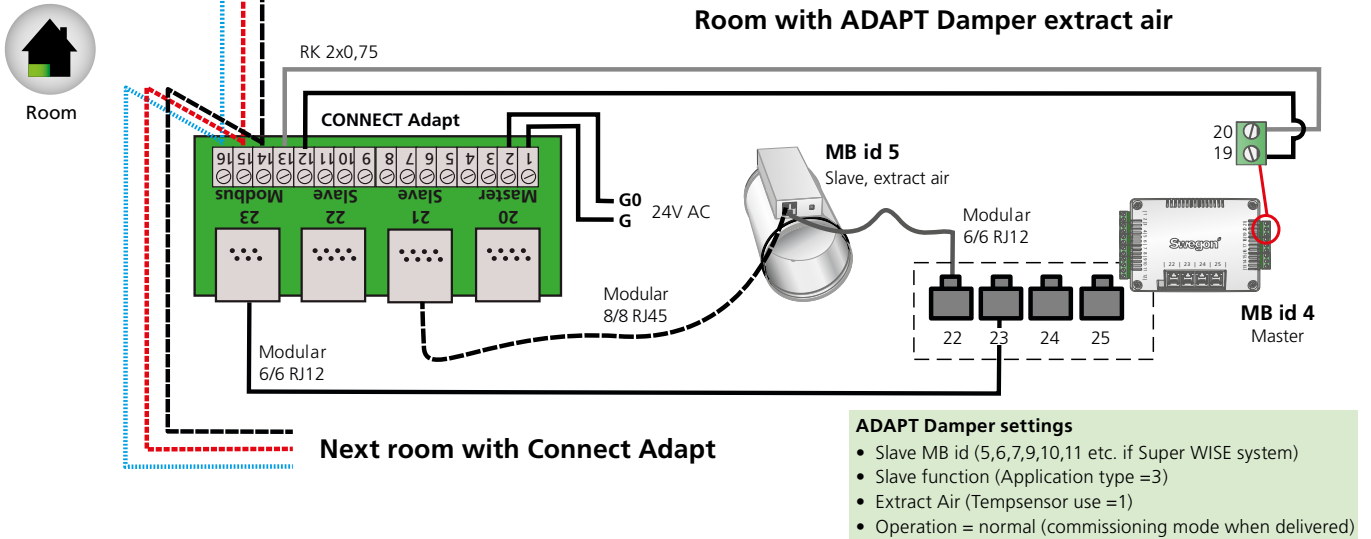
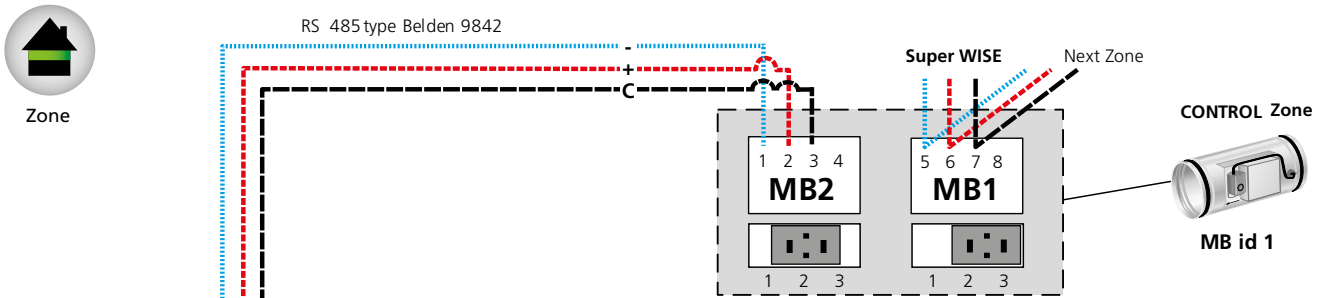

A11, B10

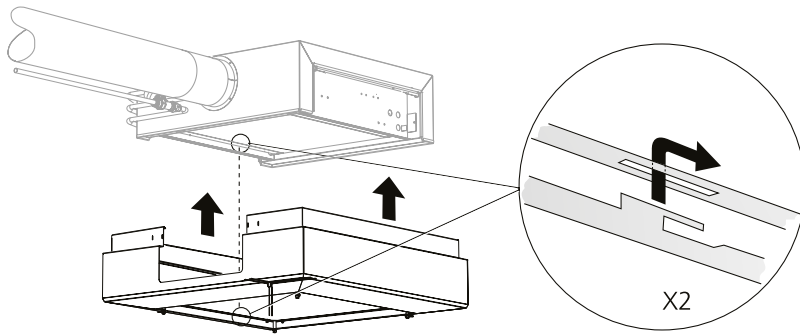

A12, B11

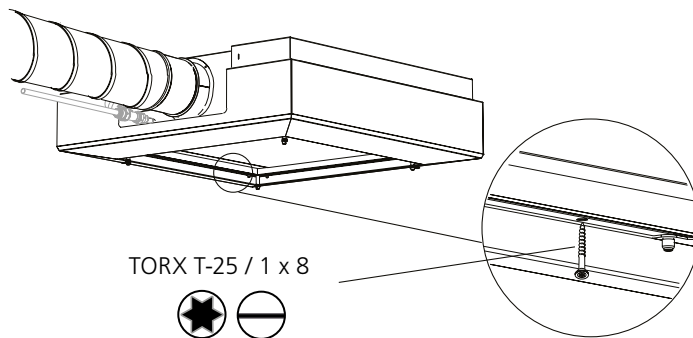

A13, B12

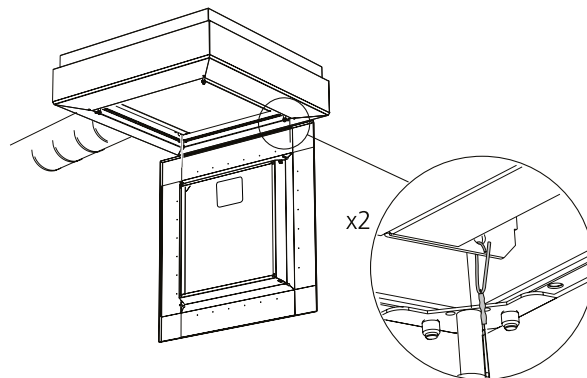

A14, B13

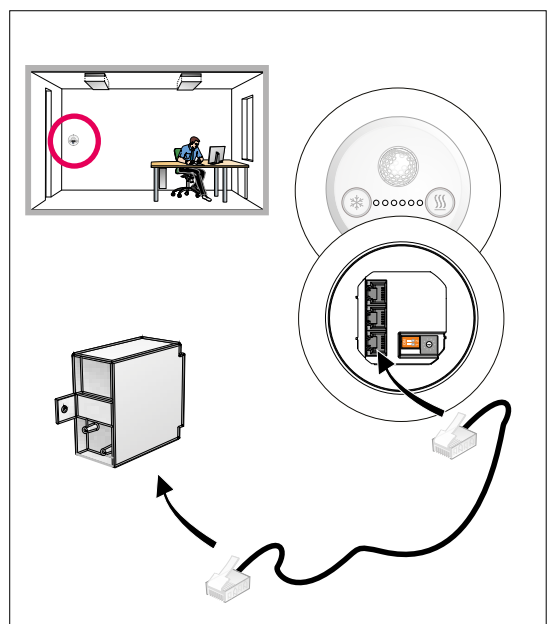
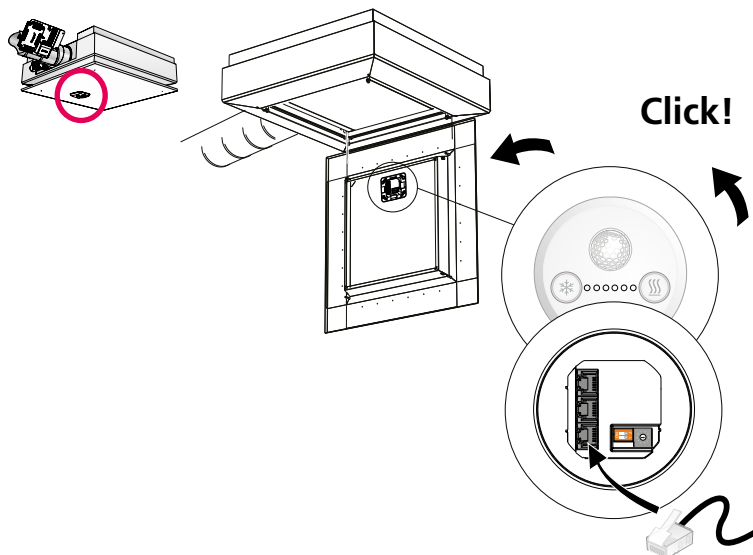

A15, B14

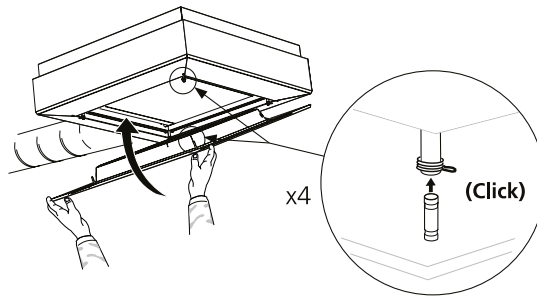

A16

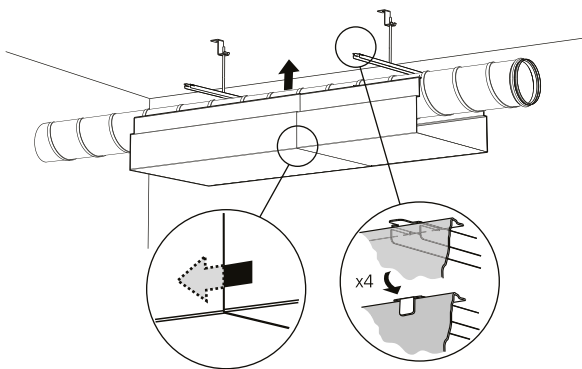

B15

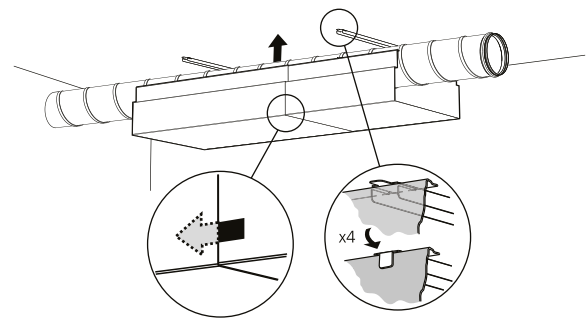

A17, B16

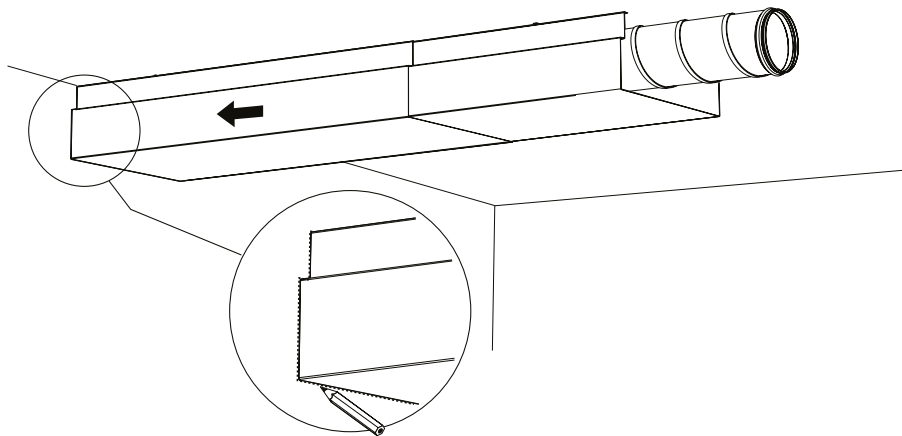

A18, B17

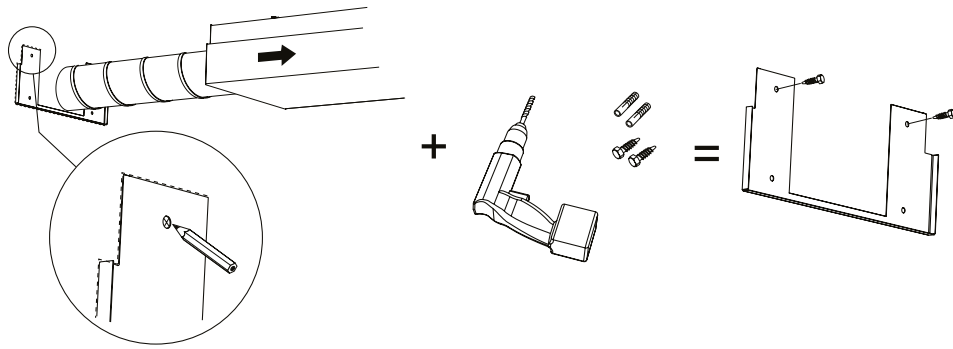

A19, B18

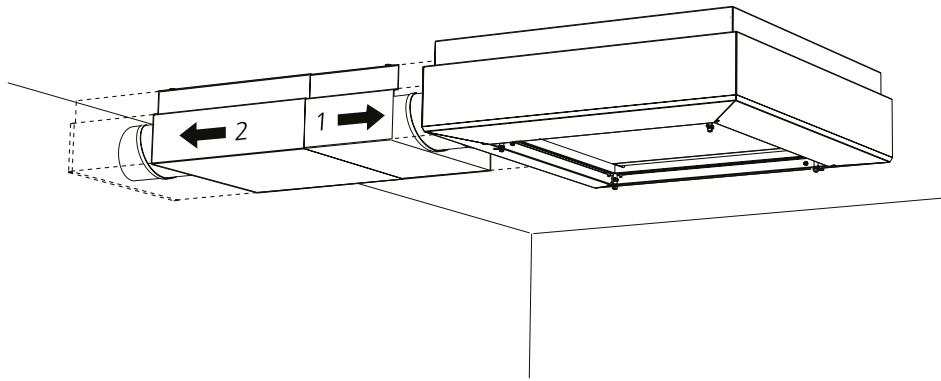

Commissioning

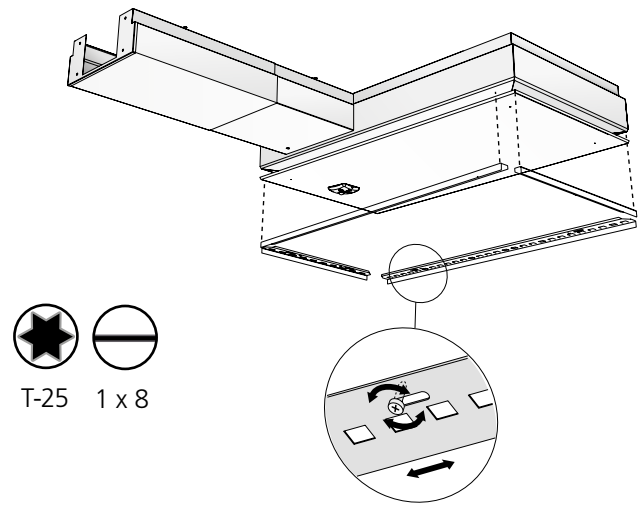
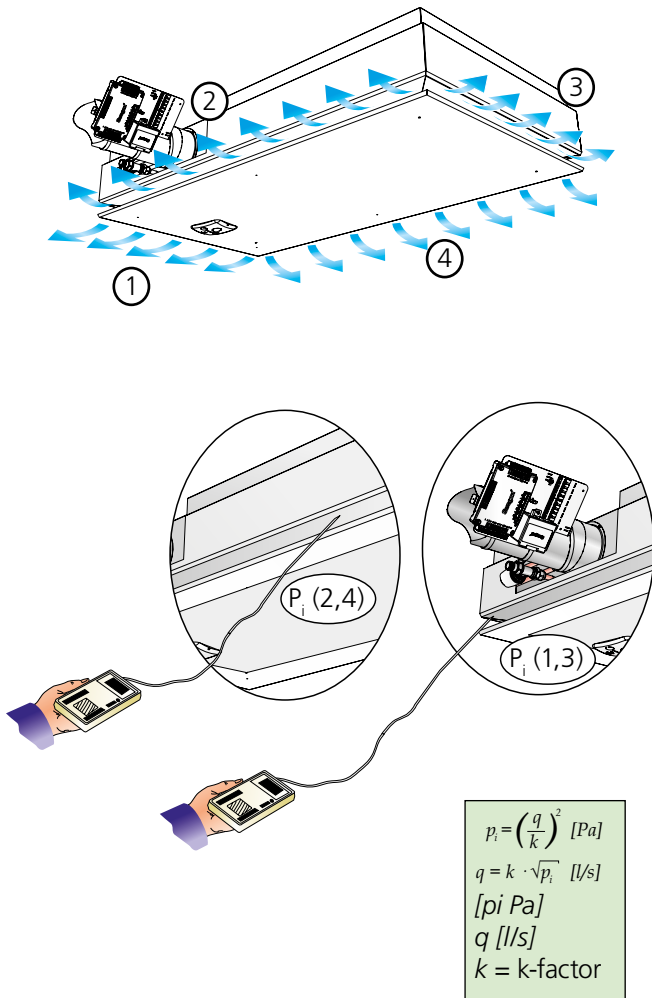

Nozzle configuration
H → M → L

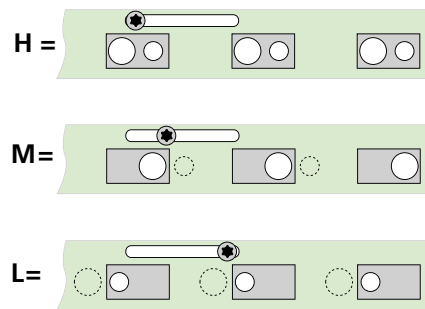

| ADAPT Parasol EX | Nozzle setting per side | Side | k-factor |
|------------------|-------------------------|------|----------|
| 690 | L | 1&3 | 0,253 |
| 690 | L | 2&4 | 0,253 |
| 690 | M | 1&3 | 0,44 |
| 690 | M | 2&4 | 0,44 |
| 690 | H | 1&3 | 0,693 |
| 690 | H | 2&4 | 0,693 |
| 1290 | L | 1&3 | 0,253 |
| 1290 | L | 2&4 | 0,665 |
| 1290 | M | 1&3 | 0,44 |
| 1290 | M | 2&4 | 1,16 |
| 1290 | H | 1&3 | 0,693 |
| 1290 | H | 2&4 | 1,825 |

- ① $k(1+3) + p_i(1,3) \Rightarrow q(1+3)$
The K-factor of the short sides together with the commissioning pressure reading of these equals the flow of the short sides, 1&3.
- ② $k(2+4) + p_i(2,4) \Rightarrow q(2+4)$
The K-factor of the long sides together with the commissioning pressure reading of these equals the flow of the long sides, 2 & 4.
- ③ $q_{tot} = q(1+3) + q(2+4)$
The product's total flow is the sum of the above.

NB! $p_i(1,3) \neq p_i(2,4)$

NOTE: The commissioning pressure is different for the long sides (2 & 4) and the short sides (1 & 3).

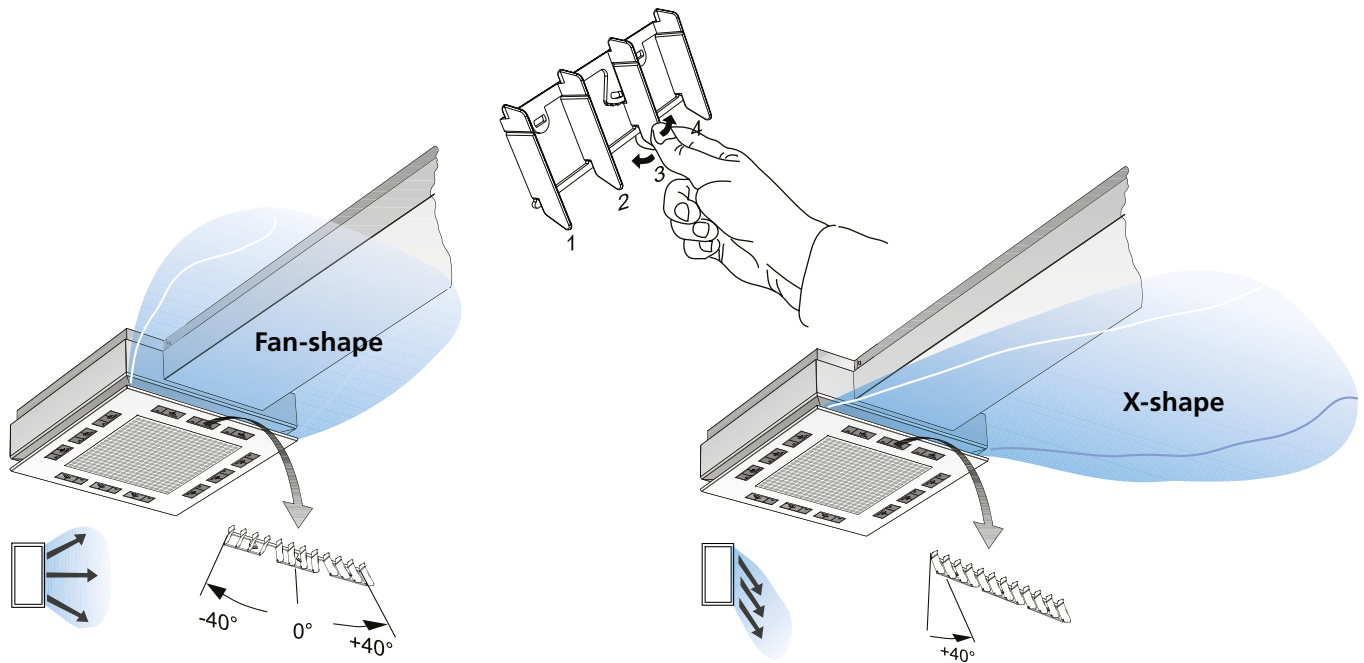

Commissioning/Checking the airflows

Constant pressure in the zone with the CONTROL Zone damper or similar damper.

- Check that all the WISE products are energized.
- Make sure that all the ADAPT Parasol EX modules have their correct K-factors.
- Make sure that all the modules are set to the max. flow commissioning mode. (On delivery, the product is set to this mode, 3 blue LEDs + 3 red LEDs are lit).
- Connect up to the control unit on the ADAPT Parasol EX (see separate SWICCT instructions) and carry out a performance check.
- Test the operating modes, the min./max. flows, open/close the actuators. If the ADAPT Parasol EX has been configured at the factory, check that the settings agree with the project design data. If the module is an ADAPT Parasol EX stock (stocked product), it must be programmed according to the data for which the product has been calculated. Make also sure that the Modbus addresses agree if SuperWISE or some other BMS system will be used.
- If SuperWISE will be used, make sure that all products are in the SuperWISE tree structure. If all the products are not in the tree structure, look over the Modbus addresses via SWICCT and check cables and connections. (See the separate instructions for the SuperWISE).
- Make sure that the pressure sensor and sensor module have the correct Modbus address. The Master must have a 0 setting on the pressure sensor and sensor module. Set the Slaves, if required, in number sequence: 1, 2, 3, 4, 5, 6, 7, 8, 9
- Before you begin commissioning, make sure that the air handling unit is started up and the fire damper, if required, is fully open and that the zone damper is in full operation.
- Check the flow compared to the max. flow in the zone, adjust the pressure set point until the correct flow is obtained with TUNE Control. If Max. flow is not achieved, it will be necessary to close another/other zone damper(s).
- The reference product can be found, i.e. the one with the greatest deviation from the design max. flow, by measuring the max. flow of all the ADAPT Parasol EX modules in the zone.
- Measure and record the airflow with the damper set to the max. position on the reference ADAPT Parasol EX in the zone. Reset the module to the min. flow setting, measure and record the airflow.
- Set the module back to the max. flow setting.
- Carry out the same procedure for all the ADAPT Parasol EX modules in the zone.
- Decrease the pressure set point on the zone damper if pressure is needed for other zones, for example: 5 Pa.
- Commission the remaining zones following the same procedure.
- Check/ adjust the previous shut off zones in the same way.
- Reset the pressure set points on all the zone dampers.
- Identify the reference zone, i.e. the zone with the lowest flow compared with the design max. flow (for example by checking relevant flow across each zone damper using the TUNE Control hand-held terminal).
- Set the min. flow on a number of ADAPT Parasol EX modules or use the zone damper for setting the min. flow so that the ventilation system responds to the simultaneous load.
- Adjust the pressure set point of the air handling unit until the zone damper of the reference zone is 85 – 90% open. (Managed by the SuperWISE if one is used).
- Reset all the settings and set all the ADAPT Parasol EX to the normal operation setting.
- Check and measure the max. flow and min. flow with the SWICCT or the SuperWISE.

Menu:

To reach the menu, hold the left-hand and right-hand buttons down for five seconds.

With the left-hand button (*) you advance through the menus. With the right-hand button (≡) you confirm your selection.

Press the left-hand button and select:

1. Alarm list
2. Commissioning air
3. Commissioning water
6. Return to menu



Press the right-hand button to confirm your selection

1. Alarm list: See the complete alarm list to the right.

In the commissioning menus:

- Navigate between the menus by pressing the left-hand button
- Confirm selections by pressing the right-hand button
- When a selection has been confirmed, the blue LED will flash for about 60 seconds.
- In order to return to normal operation, select "no adjustment"

2. Commissioning, Air:

2.1. Min. airflow, no occupants ○ ● ○ ○ ● ○

2.2. Min. airflow, occupancy ● ○ ○ ○ ○ ●

2.3. Max. airflow, occupancy ● ● ● ● ● ●

2.4. Min. airflow, holiday/longer period of no occupancy ○ ○ ● ● ○ ○

2.5. No adjustment ○ ○ ○ ○ ○ ○

3. Commissioning, Water:

3.1. Open the chilled water valve ● ● ● ○ ○ ○

3.2. Open heated water valve ○ ○ ○ ● ● ●

3.3. No adjustment ○ ○ ○ ○ ○ ○

4, 5 are not used

6. Return to menu

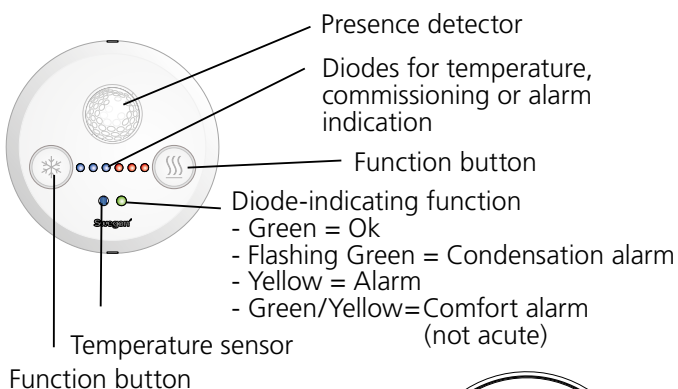

3 parallel RJ12 ports (Modbus) for connecting a controller, another sensor module or a computer, for example, by means of a Cable converter USB-RJ12

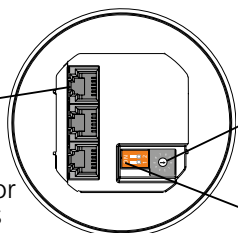

Dial for addressing the appropriate sensor module if several are used in the same loop. 10 sensormodules can be connected to the same master, and each and one of them need an unique address. Switch/Termination resistance. Switch 1 should be "on" for the last sensormodule in the loop.

Alarm list for the sensor module

| Alarm no. | Type of alarm | 32 | 16 | 8 | 4 | 2 | 1 |
|-----------|--------------------------------|----|----|---|---|---|---|
| Alarm 1 | Supply voltage low | | | | | | ● |
| Alarm 2 | Supply voltage critically low | | | | | ● | |
| Alarm 3 | Ext temp missing | | | | | ● | ● |
| Alarm 4 | Ext temp error | | | | ● | | |
| Alarm 5 | Condensation sensor error | | | | ● | | ● |
| Alarm 6 | SM temp sensor error | | | | ● | ● | |
| Alarm 7 | SM button error | | | | ● | ● | ● |
| Alarm 8 | CO ₂ sensor missing | | | ● | | | |
| Alarm 9 | VOC Error | | | ● | | | ● |
| Alarm 10 | Low pressure | | | ● | | ● | |
| Alarm 17 | SM comm error | | ● | | | | ● |
| Alarm 18 | Slave comm error | | ● | | | ● | |
| Alarm 19 | Pressure sensor comm error | | ● | | | ● | ● |
| Alarm 20 | VOC sensor comm error | | ● | | ● | | |
| Alarm 21 | No master request (slave) | | ● | | ● | | ● |
| Alarm 22 | Slave incompatible version | | ● | | ● | ● | |
| Alarm 25 | Heating comfort alarm | | ● | ● | | | ● |
| Alarm 26 | Cooling comfort alarm | | ● | ● | | ● | |
| Alarm 27 | Temp. Set point overlap alarm | | ● | ● | | ● | ● |
| Alarm 28 | Air quality comfort alarm | | ● | ● | ● | | |
| Alarm 29 | Condensation | | ● | ● | ● | | ● |
| Alarm 33 | 24 V Out 1 overload error | ● | | | | | ● |
| Alarm 34 | 24 V Out 2 overload error | ● | | | | ● | |
| Alarm 35 | 24 V Out 3 overload error | ● | | | | ● | ● |
| Alarm 41 | Slave input common alarm | ● | | ● | | | ● |
| Alarm 42 | Slave output common alarm | ● | ● | | | ● | |

The alarm is displayed by a number of diodes when you have selected Alarm list (1) in the menu.

Each diode represents a number as shown in the table above and the numbers should be added up to form an alarm number.

Ex. The centremost blue and the two last red diodes are lit (xoxoo)

The centremost blue one corresponds to 16, the penultimate red one to 2 and the last red one to 1. The sum of these is 19, which is the alarm number.

Return to normal operation by pressing the right-hand button.

Maintenance

